

PowerTech™

4045HFU82 Diesel Engine - 100 kVA

GENERATOR SET POWER UNIT SPECIFICATIONS



Pictures

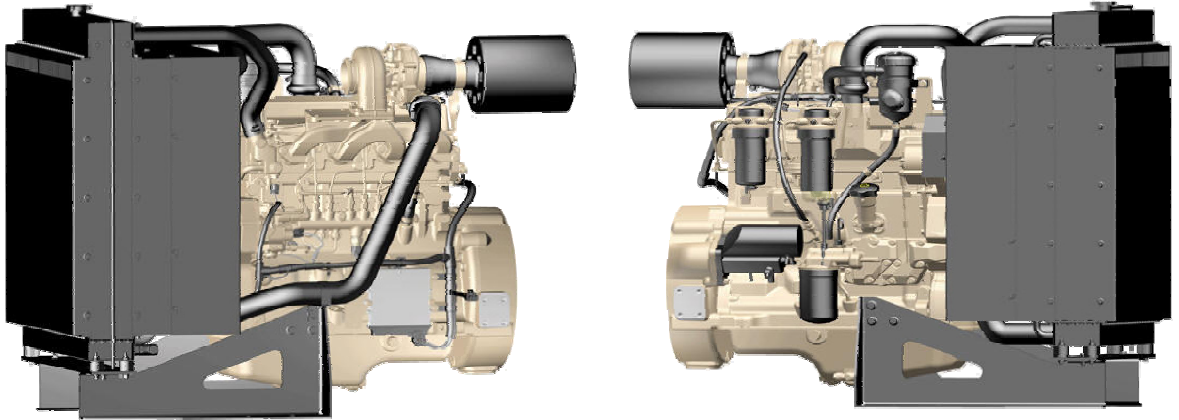

General data

Model	4045HFU82
Number of cylinders	In Line 4
Displacement – L (cu in)	4.5 (275)
Bore and stroke – mm (in)	106 x 127 (4.19 x 5.00)
Compression ratio	19.0 : 1

Injection Type	High Pressure Common Rail
Aspiration	Turbocharged (Air cooled)
Length – mm (in)	1359 (53.5)
Width – mm (in)	755 (29.7)
Height – mm (in)	1155 (45.4)
Weight, dry – kg (lb)	598 (1318)

Corresponding bare engine

4045HFG82

Ratings

Prime power at 50 Hz (1500 rpm)	94 kW (127 hp)
Standby power at 50 Hz (1500 rpm)	103 kW (140 hp)

Prime power at 60 Hz (1800 rpm)	96 kW (131 hp)
Standby power at 60 Hz (1800 rpm)	106 kW (144 hp)

Prime power at 60 Hz (1800 rpm)

Prime power is the nominal power an engine is capable of delivering with a variable load for an unlimited number of hours per year. This rating conforms to ISO 3046 and SAE J1995.

Standby power is the nominal engine power available at varying load factors for up to 500 hours per year. This rating conforms to ISO 3046 and SAE J1995. The calculated generator set rating range for standby applications is based on minimum engine power (nominal -5%) to provide 100% meet-or-exceed performance for assembled standby generator sets.

Certification

EU Stage III A

Performance data

Engine model	Hz (rpm)	Generator efficiency %	Fan power		Power factor	Calculated generator set output			
			kW	hp		Prime		Standby	
						kWe	kVA	kWe	kVA
4045HFG82	50 (1500)	88-92	3.9	5.2	0.8	79-82	98-103	87-91	108-114
4045HFG82	60 (1800)	88-92	6.7	8.9	0.8	78-82	98-103	87-91	108-114

Dimensions

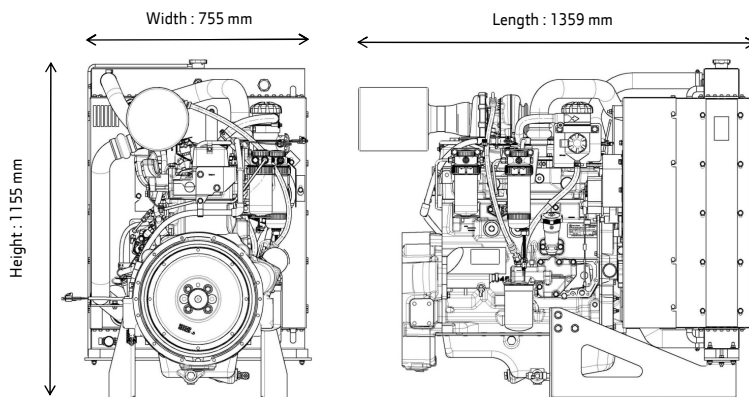

Features and benefits

High performance

- High Pressure Common Rail System with electronic control and air to air after cooling provides exceptional power density, load response characteristics and fuel efficiency
- Turbocharger characteristics matched for optimum performance at 1500 rpm
- Fan designed to minimise power consumption and thus maximise fuel efficiency

Reliability and durability

- Off highway industrial engine base
- Heavy duty air cleaner available for the most severe working environments
- Two stages fuel filtration with water detection
- Default monitoring by electronic control and possibility of alarms, derates or shut-down

Cost efficient design

- 2 valves head, simple turbocharger

Easy to use

- 50 / 60 Hz frequency switchable
- See through expansion tank for quick coolant level check
- Easy modification of governing parameters in case of multiple Genset Usage (paralleling)
- Electronic systems allows engine performances monitoring and easy diagnostic
- Direct injection provides excellent cold start-ability

Maintenance and service

- All control and maintenance points located on RH side and easily accessible
- Control and diagnostic via CAN bus communication
- 500 hours oil change interval as standard
- Oil drain valve available
- Developed for prime power usage
- Replaceable cylinder liners for easy engine overhaul

Ease of integration

- Standard fan guard and belt guard conform to EU machinery directive
- Cooling package designed for enclosures up to 200 Pa air restrictions and 47°C ambient air temperature
- Blower fan as standard
- Same Power Unit for 50 and 60 Hz applications
- Front feet design includes cooling package mountings
- Integrated radiator and charge air cooler enable a compact design
- Specific options available for marine applications.

Environment friendly

- High Pressure Common Rail system : higher injection pressure, variable timing control and multiple injections enable to meet emissions while reducing fuel, consumption, noise and vibrations levels
- Clean engine environment with optional crankcase ventilation system
- Low noise fan design